



HEXAGON

PC-DMIS CMM Check

Product presentation

2025-01-14 Customer Solutions Wetzlar

CMM monitoring based on ISO 10360

In order to ensure traceable measurement results, a regular intermediate check of the accuracy of the coordinate measuring machine is necessary. For this reason, the "CMM Check" software for PC-DMIS was developed.

This intuitively operated tool supports CMMs that are equipped with switching or analogue touch probes and optional articulated heads or rotary tables.

With the "CMM Check" software, extensive statements can be made quickly, e.g. on volumetric length measurement deviations, probing deviations in scanning mode, multiple probe deviation, etc. Various plausibility checks prevent operating errors.

The intermediate test of the coordinate measuring machine is carried out on a calibrated test body from eumetron GmbH.

Depending on the position of the test body and the number of measurements, the accuracy of individual, multiple or all axes can be verified.

The evaluation of the tests takes place with reference to valid standards by means of the software "CMM Monitoring" from the company eumetron GmbH in the measurement protocol (PDF format).

The "CMM Check" software is available for download at: https://downloads.ms.hexagonmi.com/PC-DMIS_Solution_Modules/PC-DMIS_CMM-CHECK. Use requires a valid license.

Aim and use of the software

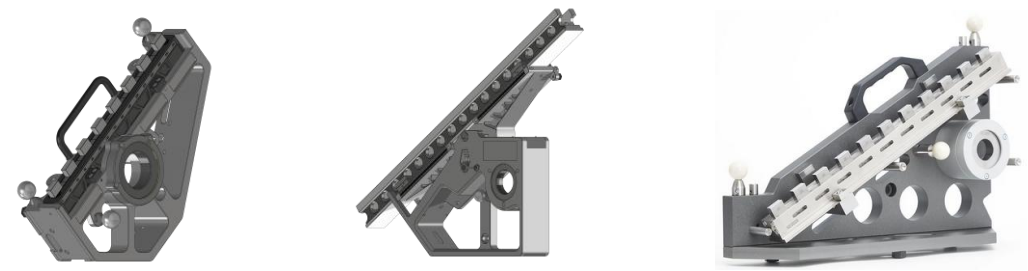

- The CMM-Check software for PC-DMIS is used for the parameterized measurement of the artefact and the transfer of the measurement results to the evaluation software from eumteron GmbH.
- The measurements are based on the DIN EN ISO 10360 series of standards and are used exclusively for monitoring and interim testing of a coordinate measurement machine and do not replace regular inspections by the technical service department.

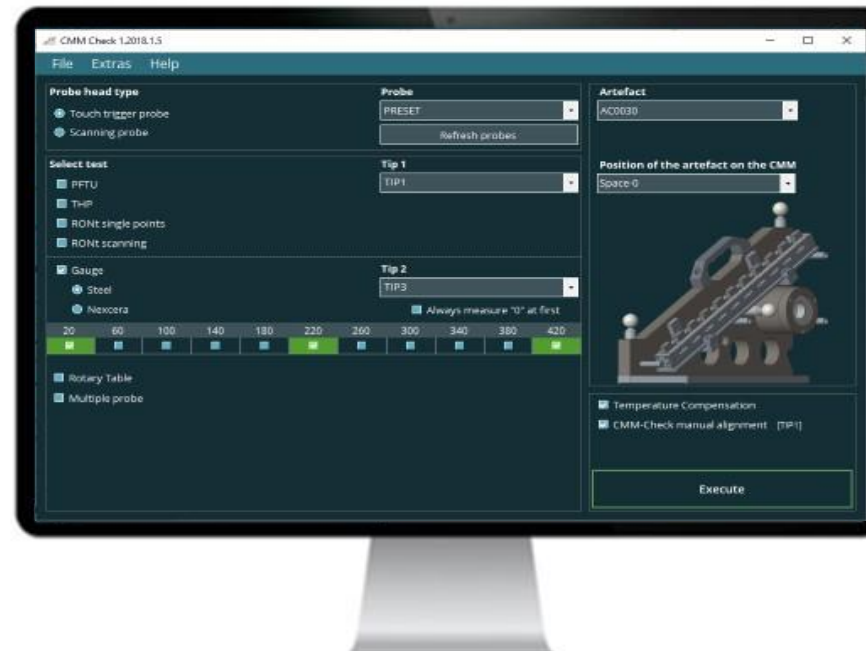

What is needed?

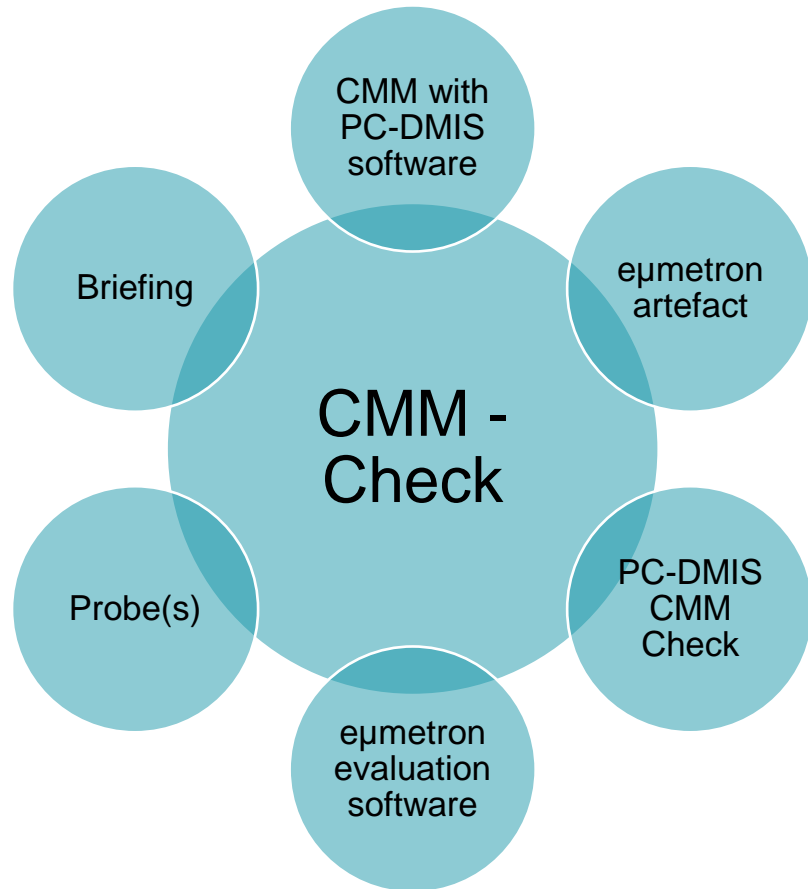

- The complete package is distributed by AfM Technology GmbH.
- The PC-DMIS CMM-Check module is maintained as part of the PC-DMIS software maintenance contract.

Artefact CMM-Check 2.0 from eumetron GmbH

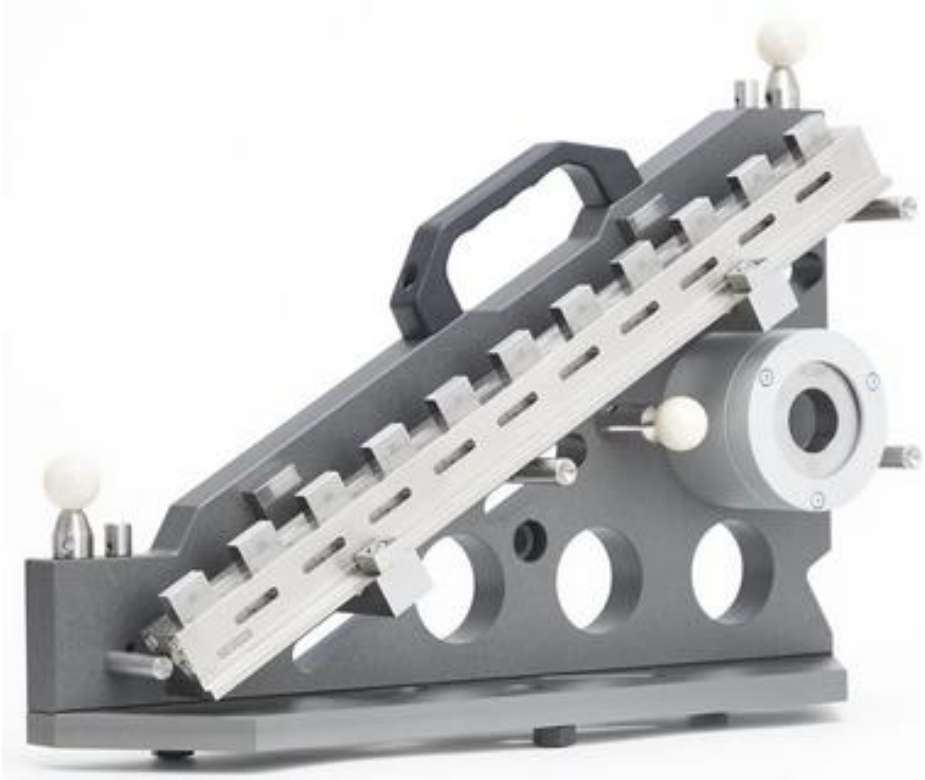

Technical data:

Ceramic sphere:
25 mm

Steel ring:
30 mm

Length dimension:
300 mm, 20-step

Optional:
Additional ceramic sphere for rotary table

<https://www.eumetron.de/en-gb/artefacts-and-standards>

Artefact I.O.360 Check medium from AfM

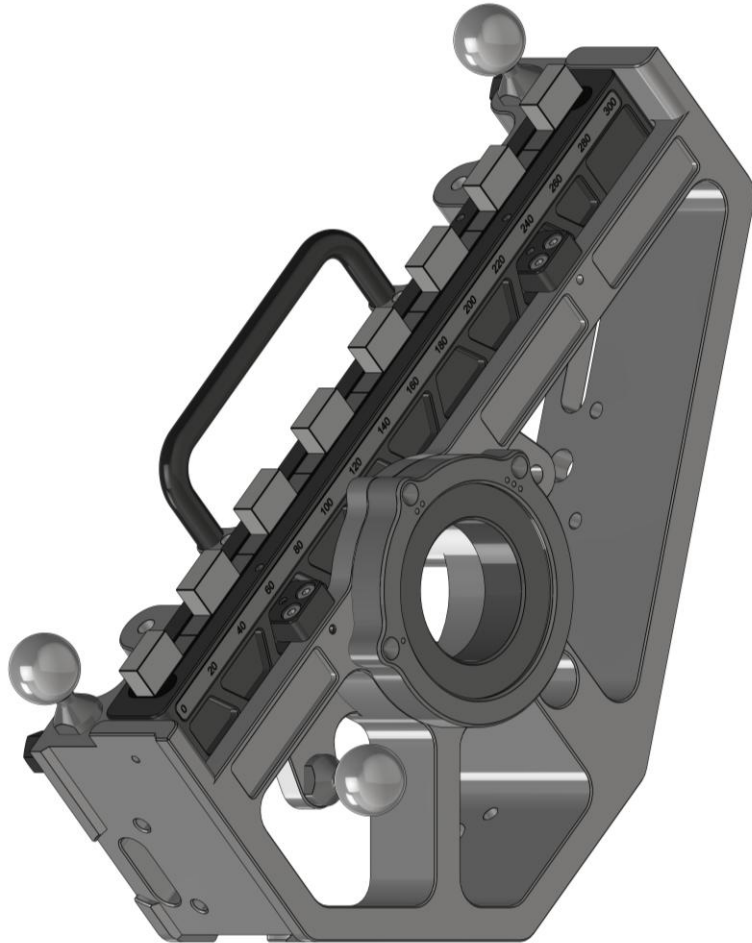

Technical data:

Ceramic sphere:
25 mm

Steel ring:
30 mm

Length dimension:
300 mm, 20-step

Optional:
Additional ceramic sphere for rotary table

<https://en.afm-tec.info/i-o-360-check>

Artefact I.O.360 Check large from AfM



Technical data:

Ceramic sphere:
25 mm

Steel ring:
50 mm

Length dimension (Koba or IST):
300 mm to 700 mm

Optional:
Additional ceramic sphere for rotary table

<https://en.afm-tec.info/i-o-360-check>

Normal using the example of CMM Check 2.0 test specimens

RT-Spheres (optional)

- Checking the four-axis deviation with rotary table according to DIN EN ISO 10360-3
- DAKks-calibration

Base body

- Bending resistant
- Can be placed in different positions on the CMM.

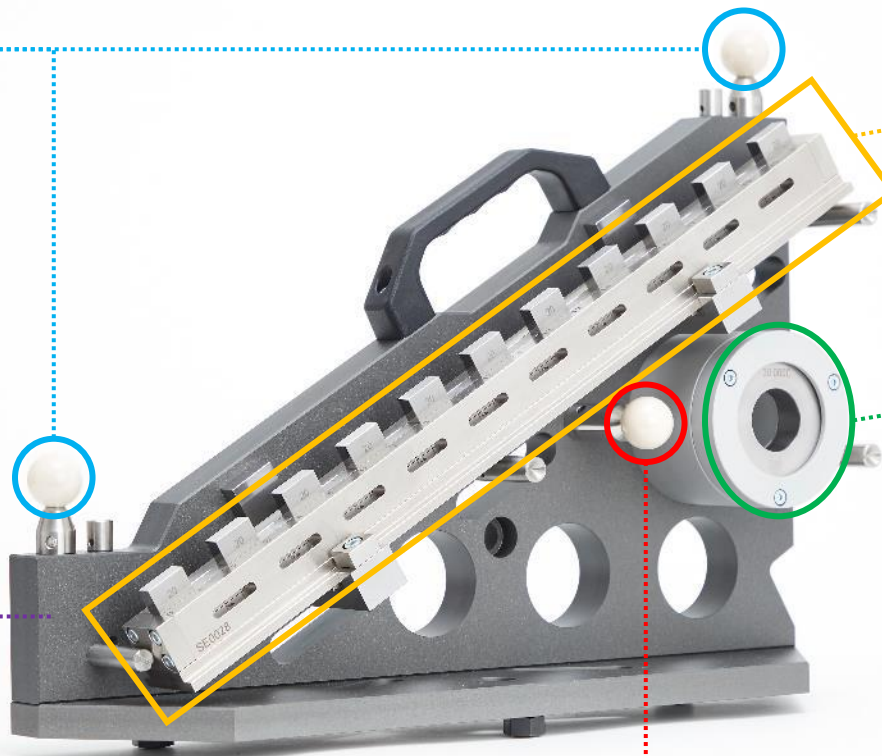

Step gauge

- Made of steel or ceramic cordierite (Nexcera)
- DAKks-calibration

Steel ring gaug

- DAKks-calibration

Ceramic sphere

- Diameter $D = 25 \text{ mm}$
- DAKks-calibration

Supported machine hardware

- In principle, all stationary CNC coordinate measuring devices (size $\geq 500 \times 500 \times 500 \text{mm}$) are supported, which are operated with PC-DMIS.
- Mobile measuring arms are currently not supported.
- Rotary table option is supported



CMM-Check 2.0 | Recommended styli configuration



LSP-S2 / LSP-S2 Scan+ / HP-S-X5(HD)		
Article number	Thread	Article description
M00-813-101-000	M5	HP-S-X5/LSP-S2/S4 stylus holder (1x M5)
M00-813-125-000	M5	HP-S-X5/LSP-S2/S4 stylus holder with cube 23x23 (L60)
060-694.056-000	M5	M5 stylus (R-8-TC-6-L90)
M00-694-109-000	M5	Stylus M5 L80mm / ML61mm / Ruby ball Dk12mm



HP-S-X3C		
Article number	Thread	Article description
M00-114-100-000	M5	HP-S-X3 stylus holder (1x M5)
M00-114-101-000	M5	M5 cube 15x15 (DA) for HP-S-X3
060-694.056-000	M5	M5 stylus (R-8-TC-6-L90)
M00-694-109-000	M5	Stylus M5 L80mm / ML61mm / ruby ball Dk12mm



HP-S-X1C		
Article number	Thread	Article description
M00-694-209-000	M3	HP-S-X1C/H stylus holder (1x M3)
M00-694-270-000	M3	HP-S-X1C/H stylus holder with star holder (5x M3)
M00-694-222-000	M3	M3-stylus (R-8-CF-5-L50)
M00-694-241-000	M3	M3-stylus (R-8-CF-5-L75)

CMM-Check 2.0 | Recommended styli configuration



HP-S-X1S		
Article number	Thread	Article description
M00-694-200-000	M3	HP-S-X1S stylus holder (1x M3)
M00-694-222-000	M3	M3-stylus (R-8-CF-5-L50)

HP-S-X1H		
Article number	Thread	Article description
M00-694-209-000	M3	HP-S-X1C/H stylus holder (1x M3)
M00-694-222-000	M3	M3-stylus (R-8-CF-5-L50)

Touch Trigger Probes		
Article number	Thread	Article description
03939302		HP-TM-SF stylus holder
03939614		HP-THD-MF stylus holder
03969276		R/CF

The evaluation software of eµmetron GmbH

- The eµmetron evaluation software (CMM Monitoring) is linked to the hardware of the test specimen, i.e. a software license must also be purchased for each artefact.
- A software license can be used on any number of CMMs. If the machine park expands, no additional license purchase is necessary.
Condition: the dongle with the license must be connected to the CMM to be tested on the PC.
- eµmetron offers customers a software support contract. 1st Level Support is provided by eµmetron.
- The software consists of a basic license and the evaluation software for the CMM Check. The basic license can also be used for other solutions from eµmetron.
- Q-DAS output is optional.
- The rotary table option is automatically included when ordering the rotary table option in conjunction with the artefact.

Measurement procedure using the various software modules

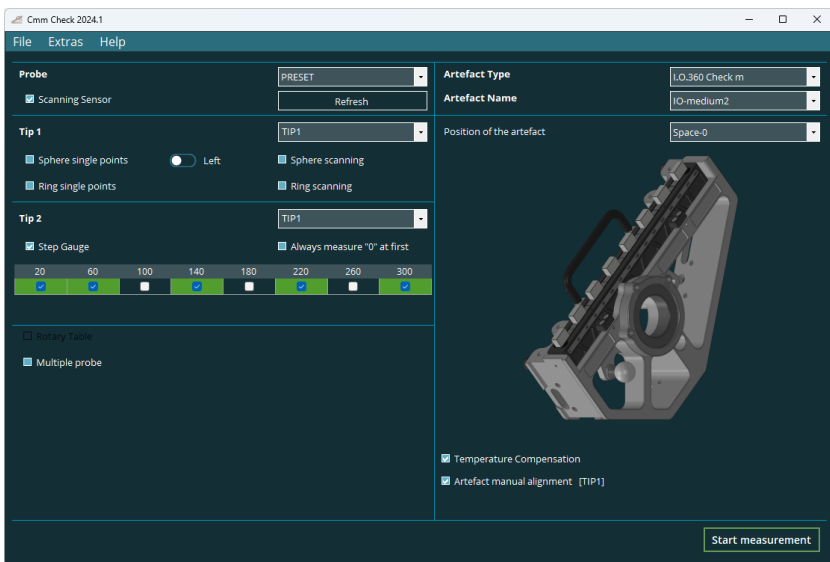

PC-DMIS CMM Check

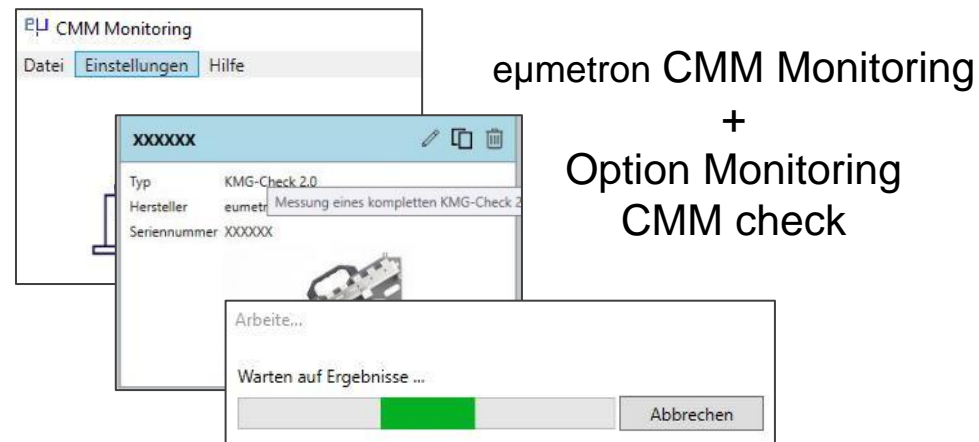

eumetron CMM Monitoring
+
Option Monitoring
CMM check

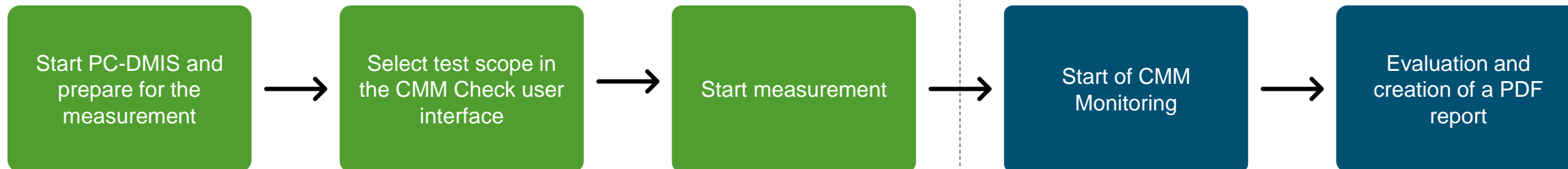

Licensing and recommended training for PC-DMIS CMM Check

- CMM-Check is linked as an option to the respective PC-DMIS license.
- This means that it is a stand-alone license per CMM.

- 1st level support can be provided by the PC-DMIS hotline.



Have we piqued your interest?

Simply download the software from our server and apply for a non-binding demo license.

https://downloads.ms.hexagonmi.com/PC-DMIS_Solution_Modules/PC-DMIS_CMM-CHECK/